



ETA-Danmark A/S
Göteborg Plads 1
DK-2150 Nordhavn
Tel. +45 72 24 59 00
Fax +45 72 24 59 04
Internet www.etadanmark.dk

Authorised and notified according
to Article 29 of the Regulation (EU)
No 305/2011 of the European
Parliament and of the Council of 9
March 2011

MEMBER OF EOTA



European Technical Assessment ETA-22/0469 of 2025/03/31

I General Part

Technical Assessment Body issuing the ETA and designated according to Article 29 of the Regulation (EU) No 305/2011: ETA-Danmark A/S

Trade name of the construction product:

BOSSONG BCR E-PLUS

Product family to which the above construction product belongs:

Bonded anchor with anchor rod for use in concrete under static, quasi-static or seismic action (performance category C2)

Manufacturer:

BOSSONG SPA
Via Enrico Fermi 51
IT-24050 Grassobbio (Bg)
Tel. +39 035 3846 011
Fax +39 035 3846 012
Internet www.bossong.com

Manufacturing plant:

BOSSONG SPA
Via Enrico Fermi 51
IT-24050 Grassobbio (Bg)

This European Technical Assessment contains:

33 pages including 28 annexes which form an integral part of the document

This European Technical Assessment is issued in accordance with Regulation (EU) No 305/2011, on the basis of:

EOTA EAD 330499-02-0601, "Bonded fasteners for use in concrete"

This version replaces:

The ETA with the same number issued on 2022-09-20

Translations of this European Technical Assessment in other languages shall fully correspond to the original issued document and should be identified as such.

Communication of this European Technical Assessment, including transmission by electronic means, shall be in full (except the confidential Annexes referred to above). However, partial reproduction may be made, with the written consent of the issuing Technical Assessment Body. Any partial reproduction has to be identified as such.

II SPECIFIC PART OF THE EUROPEAN TECHNICAL ASSESSMENT

1 Technical description of product

Technical description of the product

The BOSSONG BCR E-PLUS is a bonded anchor (injection type) consisting of an injection mortar cartridge equipped with a special mixing nozzle and a steel element which is a commercial threaded rod size M8 to M30 with hexagon nut and washer or reinforcing bars (rebar) from Ø8 mm to Ø40 mm.

The steel element is placed into a drilled hole previously injected (using an applicator gun) with a mortar with a slow and slight twisting motion. The anchor rod is anchored by the bond between rod, mortar and concrete.

The anchor in the range of M8 to M30, Ø8 to Ø40 and the mortar cartridges corresponds to the drawings given in the Annex A

The characteristic material values, dimensions and tolerances of the anchors not indicated in Annexes shall correspond to the respective values laid down in the technical documentation¹ of this European Technical Assessment.

2 Specification of the intended use in accordance with the applicable European Assessment Document (hereinafter EAD)

The performances given in Section 3 are only valid if the anchor is used in compliance with the specifications and conditions given in Annex B.

The provisions made in this European Technical Assessment are based on an assumed intended working life of the anchor of 50 years and 100 years.

The indications given on the working life cannot be interpreted as a guarantee given by the producer or Assessment Body, but are to be regarded only as a means for choosing the right products in relation to the expected economically reasonable working life of the works.

¹ The technical documentation of this European Technical Assessment is deposited at ETA-Danmark and, as far as relevant for the tasks of the Notified bodies involved in the attestation of conformity procedure, is handed over to the notified bodies.

3 Performance of the product and references to the methods used for its assessment

3.1 Characteristics of product

Mechanical resistance and stability (BWR 1):

The essential characteristics are detailed in the Annex C.

Safety in case of fire (BWR 2):

No performance assessed.

Hygiene, health and the environment (BWR3):

No performance assessed

3.2 Methods of assessment

The assessment of fitness of the anchor for the intended use in relation to the requirements for mechanical resistance and stability and safety in use in the sense of the Basic Requirements 1 has been made in accordance with EOTA EAD 330499-02-0601, “Bonded fasteners for use in concrete”.

4 Assessment and verification of constancy of performance (hereinafter AVCP) system applied, with reference to its legal base

4.1 AVCP system

According to the decision 96/582/EC of the European Commission, the system(s) of assessment and verification of constancy of performance (see Annex V to Regulation (EU) No 305/2011) is 1.

5 Technical details necessary for the implementation of the AVCP system, as provided for in the applicable EAD

Technical details necessary for the implementation of the AVCP system are laid down in the control plan deposited at ETA-Danmark prior to CE marking

Issued in Copenhagen on 2025-03-31 by

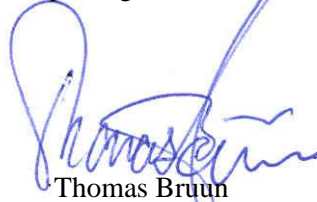

Thomas Bruun
Manager, ETA-Danmark

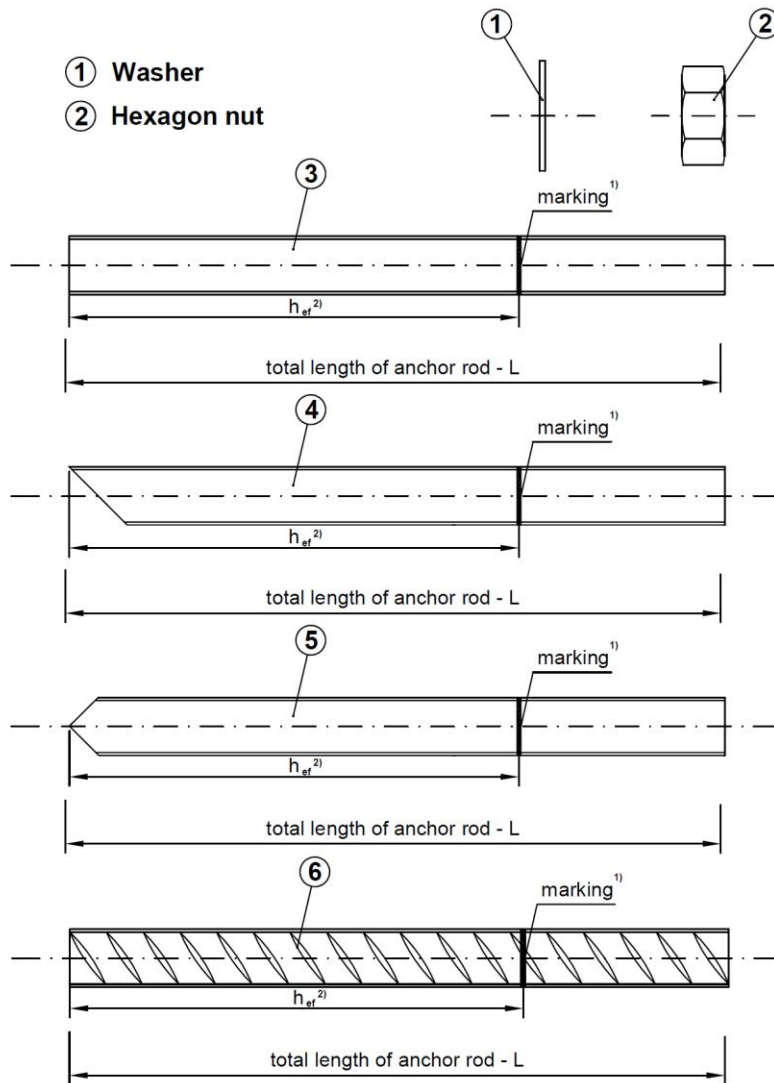

- ③ Version 1 - rod with flat end with marking on h_r
- ④ Version 2 - rod with 45° cutted end with marking on h_r
- ⑤ Version 3 - rod with V shape end with marking on h_r
- ⑥ Rebar - Deformed reinforcing bar with marking on h_r

¹⁾ Marking according to clause 1.1 of EAD 330499-02-0601

²⁾ Effective anchorage depth according to Table B1 and B2 (Annex B2 and B3)

BOSSONG BCR E-PLUS

Product description
Steel elements

Annex A1
of European
Technical Assessment
ETA-22/0469

Table A1: Threaded rods

Designation		Material			
Steel, zinc plated					
electroplated $\geq 5 \mu\text{m}$ acc. to EN ISO 4042					
hot-dip galvanized $\geq 40 \mu\text{m}$ acc. to EN ISO 1461					
Threaded rod	Property class	Characteristic steel ultimate strength	Characteristic steel yield strength	Fracture elongation	EN ISO 898-1
	4.8	$f_{uk} \geq 400 \text{ N/mm}^2$	$f_{yk} \geq 320 \text{ N/mm}^2$	$A_5 > 8\%^{1)}$	
	5.8	$f_{uk} \geq 500 \text{ N/mm}^2$	$f_{yk} \geq 400 \text{ N/mm}^2$	$A_5 > 8\%^{1)}$	
	8.8	$f_{uk} \geq 800 \text{ N/mm}^2$	$f_{yk} \geq 640 \text{ N/mm}^2$	$A_5 \geq 12\%^{1)}$	
	10.9	$f_{uk} \geq 1000 \text{ N/mm}^2$	$f_{yk} \geq 900 \text{ N/mm}^2$	$A_5 > 9\%$	
Hexagon nut	4	for class 4.8 rods			EN 898-2
	5	for class 5.8 rods			
	8	for class 8.8 rods			
	10	for class 10.9 rods			
Washer	Steel, according to EN ISO 7089; corresponding to anchor rod material				
Stainless steel A2		(Materials) 1.4301, 1.4307, 1.4567, 1.4541			
Stainless steel A4		(Materials) 1.4401, 1.4404, 1.4571, 1.4362, 1.4578			
High corrosion resistance stainless steel (HCR)		(Materials) 1.4529, 1.4565			
Threaded rod	Property class	Characteristic steel ultimate strength	Characteristic steel yield strength	Fracture elongation	EN 10088 EN ISO 3506
	50	$f_{uk} \geq 500 \text{ N/mm}^2$	$f_{yk} \geq 210 \text{ N/mm}^2$	$A_5 > 8\%^{1)}$	
	70	$f_{uk} \geq 700 \text{ N/mm}^2$	$f_{yk} \geq 450 \text{ N/mm}^2$	$A_5 \geq 12\%^{1)}$	
	80	$f_{uk} \geq 800 \text{ N/mm}^2$	$f_{yk} \geq 600 \text{ N/mm}^2$	$A_5 \geq 12\%^{1)}$	
Hexagon nut	50	for class 50 rods			EN 10088 EN ISO 3506
	70	for class 70 rods			
	80	for class 80 rods			
Washer	Steel, according to EN 10088; corresponding to anchor rod material				

¹⁾ For seismic performance category C2, $A_5 > 12\%$

Commercial standard threaded rods may be used, with:

- material and mechanical properties according to Table A3,
- confirmation of material and mechanical properties by inspection certificate 3.1 according to EN-10204:2004,
- marking of the threaded rod with the embedment depth.

Note: Commercial standard threaded rods made of galvanized steel with property class above 8.8 are not permitted in some Member States.

Filling Washer for filling annular gap



BOSSONG BCR E-PLUS

Product description
Materials (1)

Annex A2
of European
Technical Assessment
ETA-22/0469

Table A2: Reinforcing bars (Rebar)

Designation	Material
Rebar according to EN 1992-1-1:2011, Annex C	Bars and de-coiled rods Class B or C With f_{yk} and k according to NDP or NCL or EN 1992-1-1:2011/NA $f_{uk} = f_{tk} = k \times f_{yk}$ Rib height of the bar (h) in the range $0,05d \leq h \leq 0,07d$

Table A3: Injection mortars

Product	Composition
BOSSONG BCR E-PLUS two component injection mortars	Additive: quartz Bonding agent: epoxy resin

BOSSONG BCR E-PLUS

Product description
Materials (2)

Annex A3
of European
Technical Assessment
ETA-22/0469

BCR E-PLUS - from 385 to 1400 ml cartridge - side by side cartridge

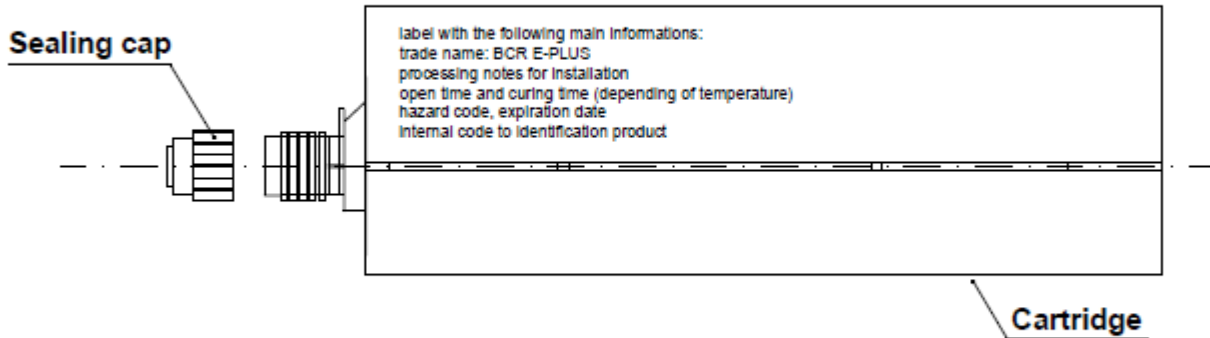

BCR E-PLUS - 600 ml - foil system

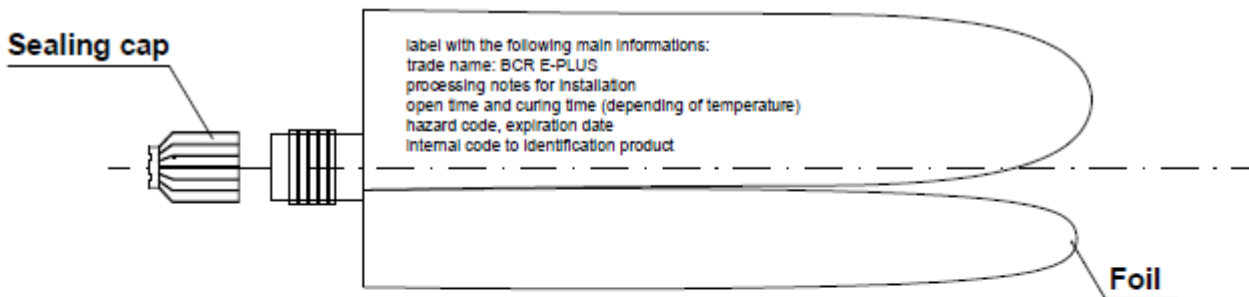

MIXER - the mixer is suitable for each type of cartridge

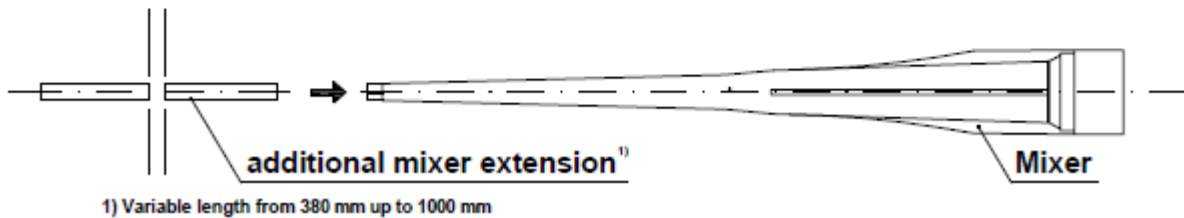

BOSSONG BCR E-PLUS

Product description
 Cartridge types and sizes

Annex A4
 of European
 Technical Assessment
 ETA-22/0469

Specifications of intended use

Use:

The anchors are intended to be used for anchorages for which requirements for mechanical resistance and stability and safety in use in the sense of the Basic Requirement 1 (EU) 305/2011 shall be fulfilled and failure of anchorages made with these products would compromise the stability of the works, cause risk to human life and/or lead to considerable economic consequences

Anchors subject to:

Static and quasi-static loads: sizes from M8 to M30 and from $\phi 8$ to $\phi 40$.

Seismic performance category C1: sizes $\phi 10$ to $\phi 32$

Seismic performance category C2: sizes M12 to M24, rods with $f_{uk} \leq 800 \text{ N/mm}^2$ and $A_5 \geq 12\%$

Working life of 50 and 100 years

Base material:

- Reinforced or unreinforced normal weight concrete of strength class C20/25 at minimum to C50/60 at maximum according to EN 206-1.
- Non-cracked concrete: sizes from M8 to M30 and from $\phi 8$ to $\phi 40$.
- Cracked concrete: sizes from M12 to M30 and from $\phi 8$ to $\phi 40$.

Temperature range:

The anchors may be used in the following temperature range:

- -40°C to $+40^\circ\text{C}$ (max. short term temperature $+40^\circ\text{C}$ and max. long term temperature $+24^\circ\text{C}$).
- -40°C to $+55^\circ\text{C}$ (max. short term temperature $+55^\circ\text{C}$ and max. long term temperature $+43^\circ\text{C}$).
- -40°C to $+80^\circ\text{C}$ (max. short term temperature $+80^\circ\text{C}$ and max. long term temperature $+50^\circ\text{C}$).

Use conditions (environmental conditions):

- Structures subject to dry internal conditions: all materials according to Table A1.
- For all other conditions according to EN 1993-1-4:2006+A2:2020 corresponding to corrosion resistance class:
Stainless steel A2 according to Annex A4, Table A1: CRC II
Stainless steel A4 according to Annex A4, Table A1: CRC III
High corrosion resistance steel HCR according to Annex A4, Table A1: CRC V

Installation:

- Dry or wet concrete (use category I1): sizes from M8 to M30 and from $\phi 8$ to $\phi 40$.
- Flooded holes with the exception of seawater (use category I2): sizes from M8 to M30 and from $\phi 8$ to $\phi 40$.
- Installation direction D3 (downward and horizontal and upwards installation): sizes from M8 to M30 and from $\phi 8$ to $\phi 40$.
- The anchors are suitable for hammer drilled holes (HD), for hollow drill bit (HDB) and for compressed air drill (CA): sizes from M8 to M30 and from $\phi 8$ to $\phi 40$. Diamond drilled holes (DD) for sizes from M16 to M30.

Design methods:

- Verifiable calculation notes and drawings are prepared taking account of the loads to be anchored. The position of the anchor is indicated on the design drawings (e. g. position of the anchor relative to reinforcement or to supports, etc.).
- Anchorages are designed under the responsibility of an engineer experienced in anchorages and concrete work.
- Anchorages under static or quasi-static loads are designed in accordance to EN 1992-4 and Technical Report TR055.
- Anchorages under seismic actions are designed in accordance to EN 1992-4 and Technical Report TR045.

BOSSONG BCR E-PLUS

Intended use
Specifications

Annex B1
of European
Technical Assessment
ETA-22/0469

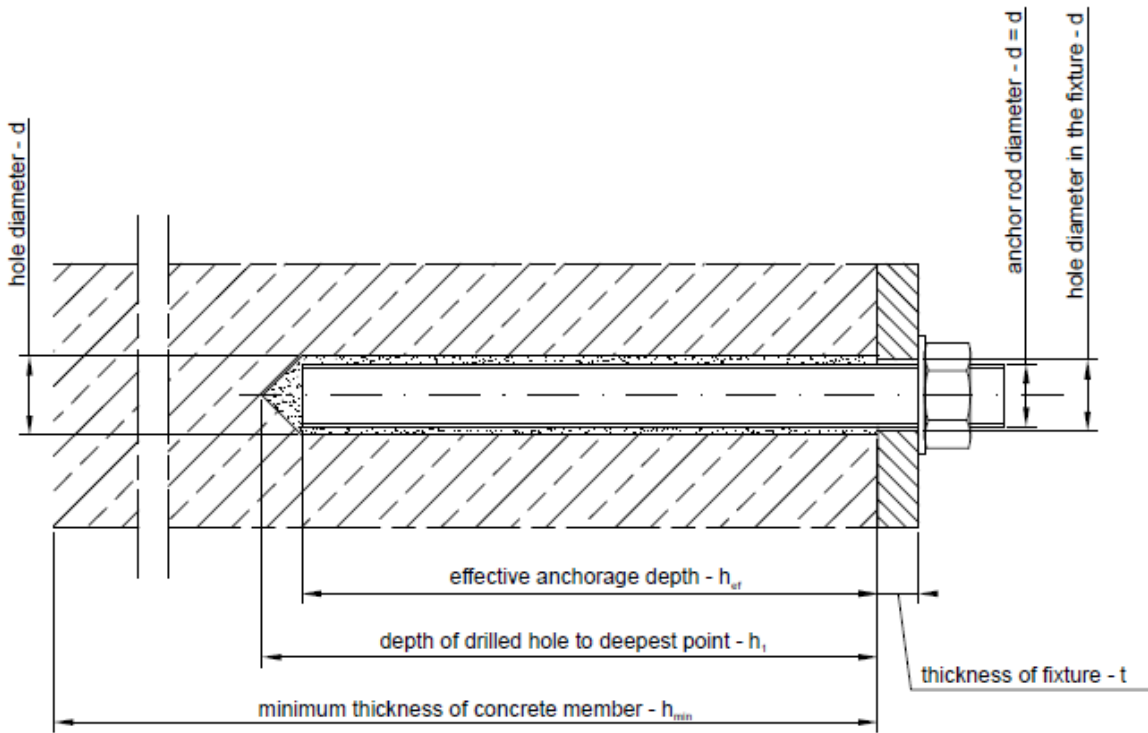

Table B1: Installation data for threaded rods

Size		M8	M10	M12	M16	M20	M24	M27	M30	
Nominal drilling diameter	d_0 [mm]	10	12	14	18	22-24	28	30	35	
Maximum diameter hole in the fixture	d_{fix} [mm]	9	12	14	18	22	26	30	33	
Effective embedment depth	$h_{ef,min}$ [mm]	60	60	70	80	90	96	110	120	
	$h_{ef,max}$ [mm]	160	200	240	320	400	480	540	600	
Depth of the drilling hole	h_1 [mm]	$h_{ef} + 5$ mm								
Minimum thickness of the concrete slab	h_{min} [mm]	$h_{ef} + 30$ mm; ≥ 100 mm			$h_{ef} + 2d_0$					
Maximum setting torque moment	T_{fix} [Nm]	10	20	40	80	130	200	270	300	
Minimum spacing	s_{min} [mm]	40	50	60	75	90	115	120	140	
Minimum edge distance	c_{min} [mm]	35	40	45	50	55	60	75	80	

BOSSONG BCR E-PLUS

Intended use
Installation data for threaded rods

Annex B2
of European
Technical Assessment
ETA-22/0469

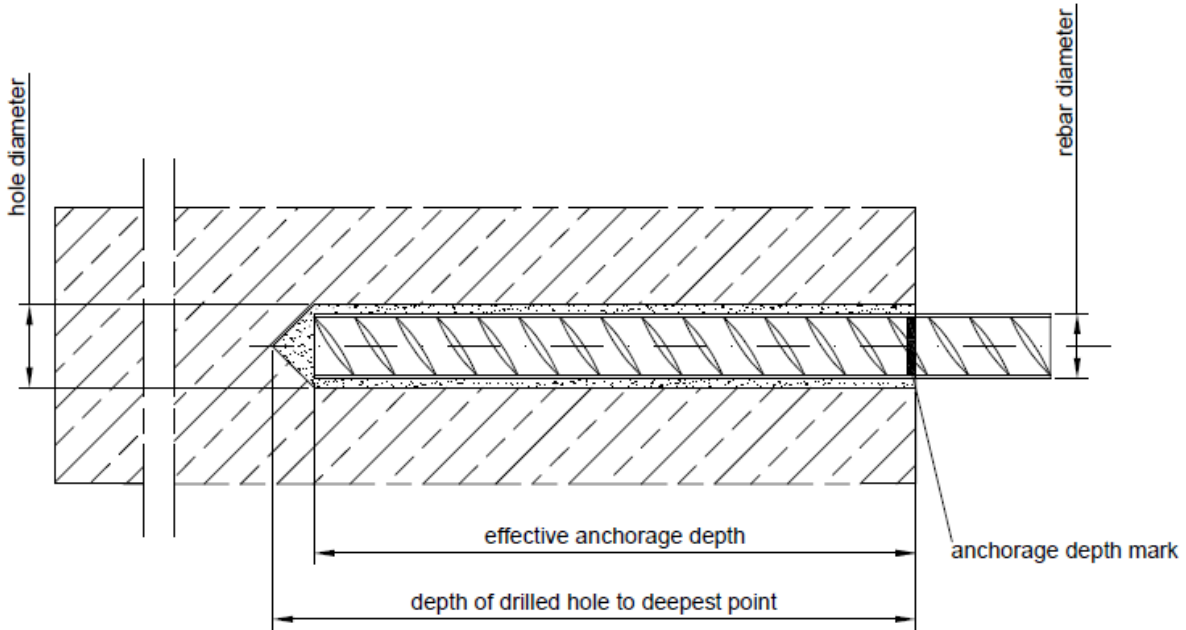

Table B2: Installation data for rebars

Size		Ø8	Ø10	Ø12	Ø14	Ø16	Ø20	Ø22	Ø25	Ø28	Ø30	Ø32	Ø40	
Nominal drilling diameter	d_0 [mm]	10-12	12-14	14-16	18	20	25	26	30-32	35	35	40	50-52	
Effective embedment depth	$h_{ef,min}$ [mm]	60	60	70	70	80	90	90	100	120	120	130	200	
	$h_{ef,max}$ [mm]	160	200	240	280	320	400	440	500	560	600	640	800	
Depth of the drilling hole	h_1 [mm]	$h_{ef} + 5 \text{ mm}$												
Minimum thickness of the concrete slab	h_{min} [mm]	$h_{ef} + 30 \text{ mm}; \geq 100 \text{ mm}$			$h_{ef} + 2d_0$									
Minimum spacing	s_{min} [mm]	40	50	60	70	80	100	105	125	140	150	160	160	
Minimum edge distance	c_{min} [mm]	35	45	45	50	50	65	65	70	75	80	80	100	

BOSSONG BCR E-PLUS

Intended use
Installation data for rebars

Annex B3
of European
Technical Assessment
ETA-22/0469

Table B3: Maximum processing time and minimum curing time

BOSSONG BCR E-PLUS			
Concrete T° [C°]	Working time	Torque time³⁾	Minimum curing time³⁾
0°C ²⁾	2 h	48 h	96 h
5°C ²⁾	1 h 15 min	24 h	48 h
10°C	1 h	12 h	24 h
15°C	45 min	6 h	18 h
20°C	30 min	4 h	12 h
25°C	20 min	4 h	10 h
30°C	15 min	3 h	5 h
35°C	12 min	3 h	5 h
40°C	8 min	3 h	5 h

- 1) The minimum time from the end of the mixing to the time when the anchor is loaded
- 2) Minimum resin temperature recommended, for injection between 5°C and 0°C, equal to 10°C.
- 3) In presence of water the curing time must be doubled
- 4) Max resin temperature of 24°C for installation at maximum setting depth

BOSSONG BCR E-PLUS

Intended use
Maximum processing time and minimum torque and curing time

Annex B4
of European
Technical Assessment
ETA-22/0469

Manual Blower pump: nominal dimensions

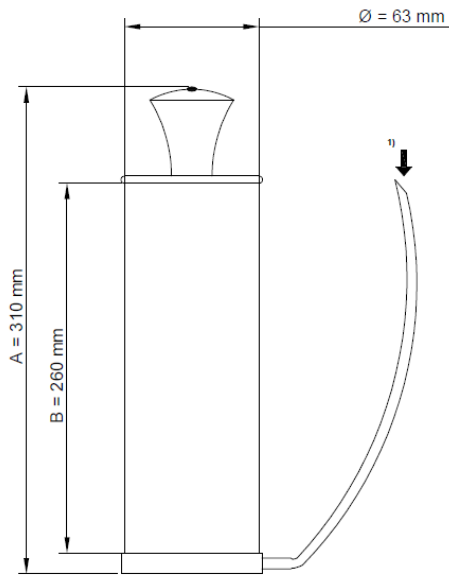

It is possible to use the mixer extension (see Annex 6) with the manual blower pump.

However it is possible to blow the hole using the mechanical air system (compressed air) also with the mixer extension



Suitable min pressure 6 bar at 6 m³/h
 Oil-free compressed air
 Recommended air gun with an orifice opening of minimum 3.5 mm in diameter

1) Position to insert the mixer extension



Mixer extension (from 380 mm to 1000 mm) with nominal diameter 10 mm

BOSSONG BCR E-PLUS

Intended use
 Cleaning tools (1)

Annex B5
 of European
 Technical Assessment
 ETA-22/0469

Table B4: Standard brush diameter for threaded rods

Threaded rod diameter		M8	M10	M12	M16	M20	M24	M27	M30
d_0	Nominal drill hole [mm]	10	12	14	18	22-24	28	30	35
d_b	Brush diameter [mm]	12	14	16	20	26	30	35	37

Table B5: Standard brush diameter for rebars

Rebar diameter		Ø8		Ø10		Ø12		Ø14
d_0	Nominal drill hole [mm]	10	12	12	14	14	16	18
d_b	Brush diameter [mm]	12	14	14	16	16	18	20

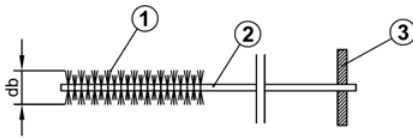

- ① Steel bristles
- ② Steel stem
- ③ Wood handle

Table B6: Special brush diameter (mechanical brush) for threaded rods

Threaded rod diameter		M16	M20	M24	M27	M30
d_0	Nominal drill hole [mm]	18	22-24	28	30	35
d_b	Brush diameter [mm]	20	26	30	32	37

Table B7: Special brush diameter (mechanical brush) for rebars

Threaded rod diameter		Ø8		Ø10		Ø12		Ø14		Ø16		Ø20		Ø25		Ø22		Ø28		Ø30		Ø32		Ø40	
d_0	Nominal drill hole [mm]	10	12	12	14	14	16	18	20	25	30-32	26	35	35	40	50-52									
d_b	Brush diameter [mm]	12	14	14	16	16	18	20	22	27	32	27	37	37	42	52-55									

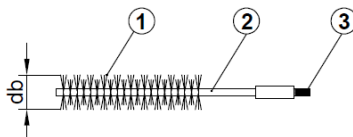

- ① Steel bristles
- ② Steel stem
- ③ Threaded connection for drilling tool extension
- ④ Extension special brush
- ⑤ Drilling tool connection (SDS connection)

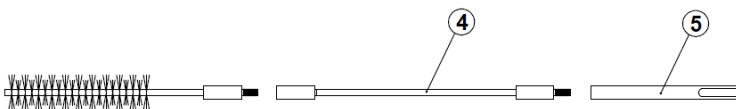

BOSSONG BCR E-PLUS

Intended use
Cleaning tools (2)

Annex B6
of European
Technical Assessment
ETA-22/0469

Hollow Drill Bit (HDB)

This drilling method is a hammer drilling method.

This drilling system removes the dust and cleans the bore hole during the drilling operation when used in accordance with the user's manual.

This drilling system include a vacuum cleaner. A suitable dust extraction system must be used. e.g. Bosch GAS 35 M AFC or a comparable dust extraction system with equivalent performance data.

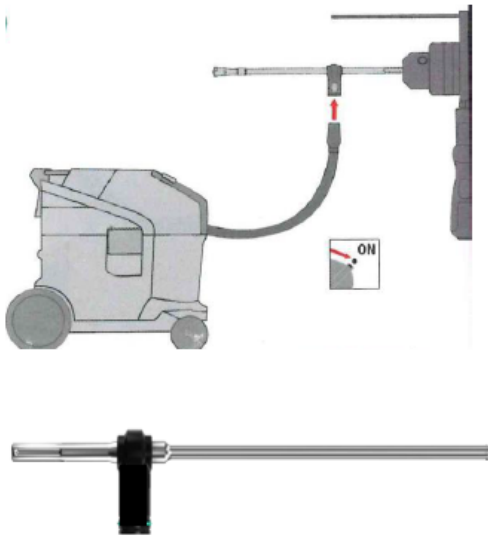

Switch-on the vacuum cleaner before to drill

Table B8: HDB perforation diameter for threaded rods

Threaded rod diameter		M8	M10	M12	M16	M20	M24	M27	M30
d₀	Nominal drill hole [mm]	10	12	14	18	22-24	28	30	35

Table B9: HDB perforation diameter for rebars

Rebar diameter		φ8	φ10	φ12	φ14	φ16	φ20	φ22	φ25	φ28	φ30
d₀	Nominal drill hole [mm]	10-12	12-14	14-16	18	20	25	26	30-32	35	35

BOSSONG BCR E-PLUS

Intended use
Hollow drill bit (HDB) specification

Annex B7
of European
Technical Assessment
ETA-22/0469

Use the mixer extension (assembled on the standard mixer) for the injection up to 300 mm if necessary.

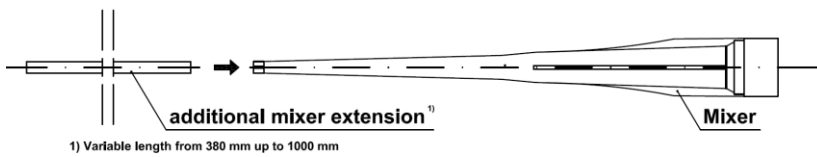

Use this system for special conditions.

Tools for installation in special condition

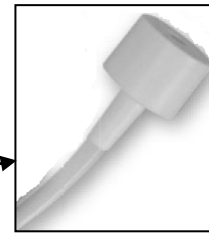
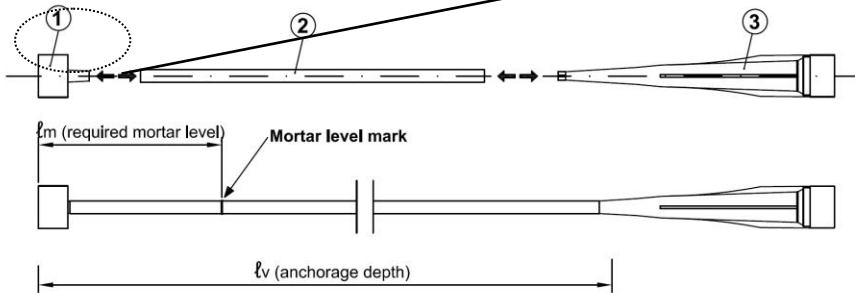

Insert the special mixer extension in the inner diameter of the injection plug up to reach the top of the plug

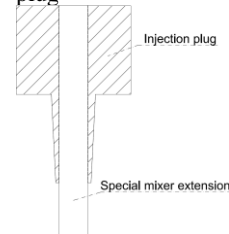

- ① Injection plug (nominal diameter according to the nominal diameter of drilled hole)
- ② Special mixer extension (variable length with nominal diameter 10 mm)
Mark the required mortar level ℓ_m and embedment depth ℓ_v with tape or marker on the injection extension. Quick estimation: $\ell_m = 1/3 \cdot \ell_v$
Continue injection until the mortar level mark ℓ_m becomes visible.
- ③ Standard mixer (suitable for all size of cartridge)

These tools allow the application in special conditions:

- installation with anchorage depth greater than 300 mm
- overhead installation.

For these applications is recommended the use of the injection pneumatic pump.



System assembled

- ① Injection plug
- ② Special mixer extension
- ③ Standard mixer
- ④ Cartridge
- ⑤ Sample of Injection pneumatic pump

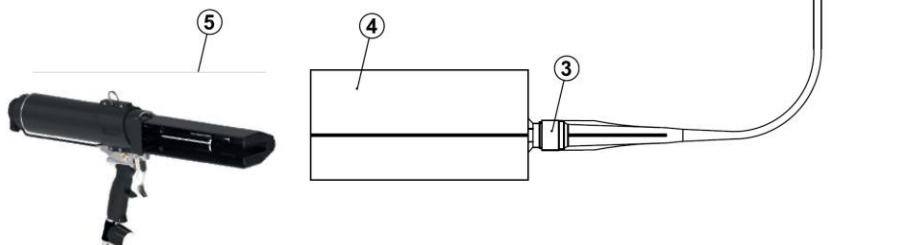





BOSSONG BCR E-PLUS

Intended use
Tools for installation (1)

Annex B8
of European
Technical Assessment
ETA-22/0469

Table B10: Mortar injection dispensers

Injection dispensers	Cartridges	Clean hole tools	Maximum depth of the drill hole
 <i>Manual</i>	385 ml 585 ml	Blower pump or compressed air and standard brush or special brush or HDB	300 mm*
 <i>Manual+ Cartridge Adaptor</i>	600 ml Foil system	Blower pump or compressed air and standard brush or special brush or HDB	300 mm*
 <i>Battery</i>	385 ml 585 ml	Compressed air and special brush or HDB	300 mm to 640 mm*
 <i>Pneumatic</i>	385 ml 585 ml 1000 ml 1400 ml	Compressed air and special brush or HDB	300 mm to 800 mm*

* Note: use the mixer extension described in Annex B8 for the injection of the mortar

BOSSONG BCR E-PLUS

Intended use
Tools for installation (2)

Annex B9
of European
Technical Assessment
ETA-22/0469

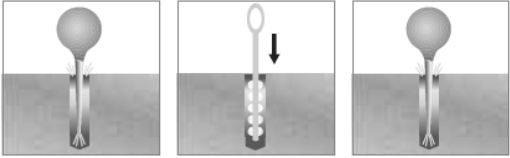
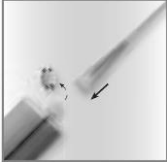
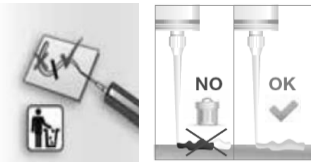
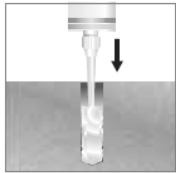
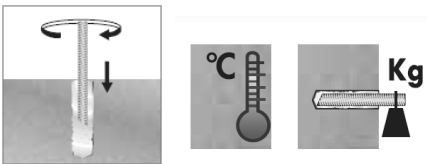
1		<p>Drill the hole with the correct diameter and depth using a rotary percussive machine. Check the perpendicularity of the hole during the drilling operation. In case of use of hollow drill bit (Annex B7) proceed directly to the point 3</p>
2	 <p>4x Blower Manual Pump 4x Standard Brush 4x Blower Manual Pump if necessary use a mixer extension for the blower operation (see Annex B5)</p>	<p>Clean the hole from drilling dust: the hole shall be cleaned by at least 4 blowing operations, by at least 4 brushing operations followed again by at least 4 blowing operations; before brushing clean the brush and check (see Annex B6, standard brush) if the brush diameter is sufficient. For the blower tools see Annex B5.</p>
3		<p>Unscrew the front cup, screw on the mixer and insert the cartridge in the gun.</p>
4		<p>Before starting to use the cartridge, eject a first part of the product, being sure that the two components are completely mixed. The complete mixing is reached only after that the product, obtained by mixing the two components, comes out from the mixer with a uniform color.</p>
5	 <p>if necessary, use a mixer extension for the injection (see Annex B8)</p>	<p>Fill the drilled hole uniformly starting from the drilled hole bottom, in order to avoid entrapment of the air; remove the mixer slowly bit by bit during pressing-out; filling the drill hole with a quantity of the injection mortar corresponding to 2/3 of the drill hole depth.</p>
6	 <p>ATTENTION: Use the rods dry and free oil and other contaminants</p>	<p>Insert immediately the rod, marked according to the proper anchorage depth, slowly and with a slight twisting motion, removing excess of injection mortar around the rod. Observe the working time according Annex B4. Wait the curing time according Annex B4. It can be optionally filled the annular gap between anchor and fixture with mortar.</p>
<p>BOSSONG BCR E-PLUS</p>		<p>Annex B10 of European Technical Assessment ETA-22/0469</p>
<p>Intended use Installation instruction up to 300 mm depth (HD – HDB – CA)</p>		

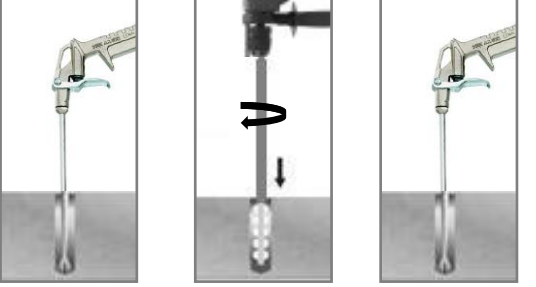
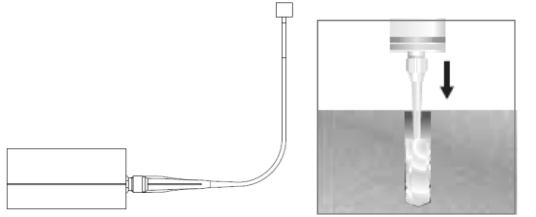
1	See point 1 Annex B10. In case of use of hollow drill bit (HDB) proceed directly to the point 3.	
2	 <p>4 x 5 seconds 4x 4 x 5 seconds ATTENTION: compressed air free oil</p>	Clean the hole from drilling dust: the hole shall be cleaned by at least 4 blowing operations (5 seconds for single operation) with compressed air, by at least 4 brushing operations with special brush followed again by at least 4 blowing operations (5 seconds for single operation) with compressed air. Before brushing clean the brush and check (see Annex B6, special brush) if the brush diameter is sufficient. For the blower tools see the Annex B5.
3	See point 3 Annex B10	
4	See point 4 Annex B10	
5		Before starting the injection, assemble the system according to Annex B8. After that, fill the drilled hole uniformly from the drilled hole bottom, in order to avoid entrapment of the air; remove the special mixer extension with injection plug slowly bit by bit during pressing-out; filling the drill hole with a quantity of the injection mortar corresponding to 2/3 of the drill hole depth. Procedure for overhead application is detailed in Annex B13.
6	See point 6 Annex B10	
BOSSONG BCR E-PLUS		Annex B11 of European Technical Assessment ETA-22/0469
Intended use Installation instruction up to 800 mm depth (HD – HDB – CA)		

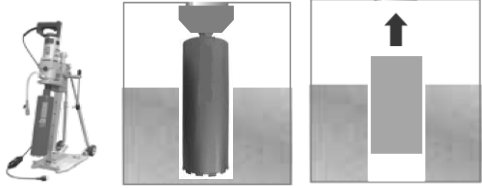
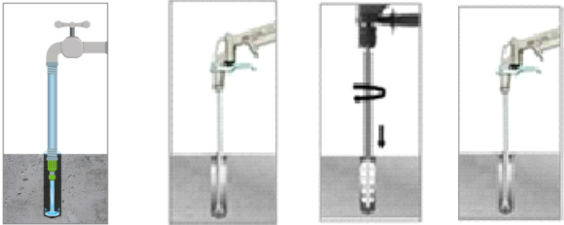
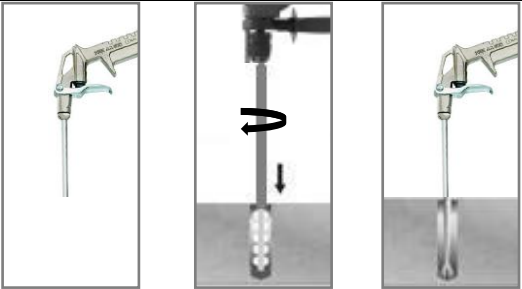
<p>1</p>		<p>Drill the hole with the correct diameter and depth using a core drill machine. Check the perpendicularity of the hole during the drilling operation. Remove completely the core from the hole.</p>
<p>2</p>	 <p>flush hole until water runs clear</p> <p>4x blower with compressed air</p> <p>4x special brush</p> <p>4x blower with compressed air</p>	<p>After operation 1, if the diamond drilling machine used has a dry cutting system proceed with the installation procedure according to the point 3.</p> <p>Instead, if it is used a wet cutting system before go to the point 4 the following operation must be done:</p> <ul style="list-style-type: none"> - flush hole 2 times by inserting a water hose to the back of the hole until water runs clear; - brush 2 times with the proper special brush. Before brushing clean the brush and check (see Annex B6, special brush) if the brush diameter is sufficient; - flush again 2 times until water runs clear; - remove all standing water completely (using for example vacuum system or compressed air free oil).
<p>3</p>	 <p>4 x 5 seconds</p> <p>6x</p> <p>4 x 5 seconds</p> <p>ATTENTION: compressed air free oil</p>	<p>Clean the hole from drilling dust: the hole shall be cleaned by at least</p> <ul style="list-style-type: none"> - 4 blowing operations (5 seconds for single operation) with compressed air - 4 brushing operations with special brush - 4 blowing operations (5 seconds for single operation) with compressed air. <p>Before brushing clean the brush and check (see Annex B6, special brush) if the brush diameter is sufficient. For the blower tools see the Annex B5.</p>
<p>4</p>	<p>After the operation above, to follow the operations from 4 to 6 on the previous Annex B9 and B10 in function of the depth of the hole.</p>	
<p>BOSSONG BCR E-PLUS</p>		<p>Annex B12</p>
<p>Procedure with diamond drilling (wet and dry) for all depths (DD)</p>		<p>of European Technical Assessment ETA-22/0469</p>

Overhead installation procedure

In addition to standard procedure, for overhead installation, following the below procedure

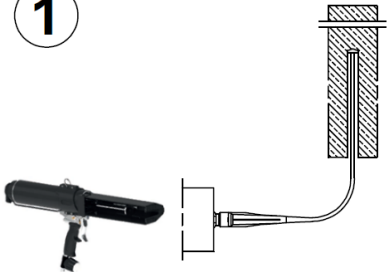
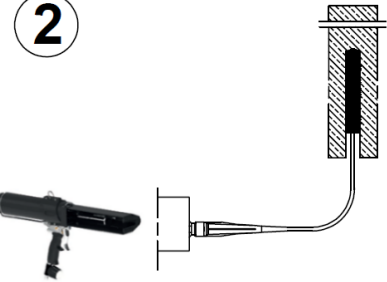
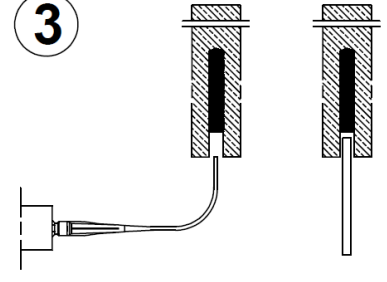
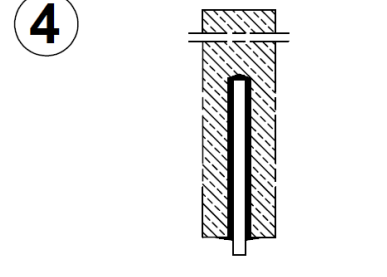
<p>1</p> 	<p>1 - Start injection</p> <p>Inject from the bottom of the hole. Use battery or pneumatic dispenser if the anchorage depth is greater than 200 mm.</p>
<p>2</p> 	<p>2 - Injection phase</p> <p>Inject the product about 2/3 of the hole depth. Remove the mixer extension slowly bit by bit during pressing-out.</p>
<p>3</p> 	<p>3 - End injection</p> <p>Remove the mixer extension. Insert immediately the steel element (turn the steel element during the insertion).</p>
<p>4</p> 	<p>4 - End installation</p> <p>To avoid the slipping of the steel element during the open time of the product (due to the steel element own weight) use a temporary interlocking element (for ex. wedge of wood)</p>

BOSSONG BCR E-PLUS

Intended use
Overhead installation instruction

Annex B13
of European
Technical Assessment
ETA-22/0469

Table C1: Characteristic values for steel tension resistance and steel shear resistance – threaded rods.

Size			M8	M10	M12	M16	M20	M24	M27	M30
Steel failure – characteristic tension resistance										
Steel class 4.8	$N_{Rk,s}$	[kN]	15	23	34	63	98	141	183	224
Steel class 5.8	$N_{Rk,s}$	[kN]	18	29	42	78	122	176	229	280
Steel class 8.8	$N_{Rk,s}$	[kN]	29	46	67	126	196	282	367	449
Steel class 10.9	$N_{Rk,s}$	[kN]	37	58	84	157	245	353	459	561
Stainless steel A2, A4, HCR class 50	$N_{Rk,s}$	[kN]	18	29	42	78	122	176	229	280
Stainless steel A2, A4, HCR class 70	$N_{Rk,s}$	[kN]	26	41	59	110	171	247	321	392
Stainless steel A4, HCR class 80	$N_{Rk,s}$	[kN]	29	46	67	126	196	282	367	449
Steel failure – characteristic tension resistance – partial factor										
Steel class 4.8	$\gamma_{Ms,N}^{1)}$	[-]	1,50							
Steel class 5.8	$\gamma_{Ms,N}^{1)}$	[-]	1,50							
Steel class 8.8	$\gamma_{Ms,N}^{1)}$	[-]	1,50							
Steel class 10.9	$\gamma_{Ms,N}^{1)}$	[-]	1,40							
Stainless steel A2, A4, HCR class 50	$\gamma_{Ms,N}^{1)}$	[-]	2,86							
Stainless steel A2, A4, HCR class 70	$\gamma_{Ms,N}^{1)}$	[-]	1,87							
Stainless steel A4, HCR class 80	$\gamma_{Ms,N}^{1)}$	[-]	1,60							
Steel failure – characteristic shear resistance without lever arm										
Steel class 4.8	$V_{Rk,s}^0$	[kN]	7	12	17	31	49	71	92	112
Steel class 5.8	$V_{Rk,s}^0$	[kN]	9	14	21	39	61	88	115	140
Steel class 8.8	$V_{Rk,s}^0$	[kN]	15	23	34	63	98	141	184	224
Steel class 10.9	$V_{Rk,s}^0$	[kN]	18	29	42	78	122	176	230	280
Stainless steel A2, A4, HCR class 50	$V_{Rk,s}^0$	[kN]	9	14	21	39	61	88	115	140
Stainless steel A2, A4, HCR class 70	$V_{Rk,s}^0$	[kN]	13	20	29	55	86	124	160	196
Stainless steel A4, HCR class 80	$V_{Rk,s}^0$	[kN]	15	23	34	63	98	141	184	224
Steel failure – characteristic shear resistance with lever arm										
Steel class 4.8	$M_{Rk,s}^0$	[Nm]	15	30	52	133	260	449	666	900
Steel class 5.8	$M_{Rk,s}^0$	[Nm]	19	37	65	166	324	561	832	1125
Steel class 8.8	$M_{Rk,s}^0$	[Nm]	30	60	105	266	519	898	1331	1799
Steel class 10.9	$M_{Rk,s}^0$	[Nm]	37	75	131	333	649	1123	1664	2249
Stainless steel A2, A4, HCR class 50	$M_{Rk,s}^0$	[Nm]	19	37	66	166	324	561	832	1124
Stainless steel A2, A4, HCR class 70	$M_{Rk,s}^0$	[Nm]	26	52	92	233	454	786	1165	1574
Stainless steel A4, HCR class 80	$M_{Rk,s}^0$	[Nm]	30	60	105	266	519	898	1331	1799
Steel failure – characteristic shear resistance – partial factor										
Steel class 4.8	$\gamma_{Ms,V}^{1)}$	[-]	1,25							
Steel class 5.8	$\gamma_{Ms,V}^{1)}$	[-]	1,25							
Steel class 8.8	$\gamma_{Ms,V}^{1)}$	[-]	1,25							
Steel class 10.9	$\gamma_{Ms,V}^{1)}$	[-]	1,50							
Stainless steel A2, A4, HCR class 50	$\gamma_{Ms,V}^{1)}$	[-]	2,38							
Stainless steel A2, A4, HCR class 70	$\gamma_{Ms,V}^{1)}$	[-]	1,56							
Stainless steel A4, HCR class 80	$\gamma_{Ms,V}^{1)}$	[-]	1,33							

Fracture elongation threaded rod for seismic C2 must be $A_s \geq 12\%$.

Steel classes 10.9 are not covered for seismic application.

¹⁾ In the absence of national regulation

BOSSONG BCR E-PLUS

Performances

Characteristic values for steel tension resistance and steel shear resistance for threaded rods

Annex C1
of European
Technical Assessment
ETA-22/0469

Table C2: Characteristic values tension resistance load in non-cracked concrete for threaded rod under static and quasi-static loads for 50 and 100 years

Size	M8	M10	M12	M16	M20	M24	M27	M30		
Steel failure										
Characteristic resistance	$N_{Rk,s}$	[kN]	See Annex C1 – Table C1							
Partial factor	$\gamma_{Ms,N}$	[-]	See Annex C1 – Table C1							
Combined pull-out and concrete cone failure in non-cracked concrete C20/25 for HD – HBD and CA										
Characteristic bond resistance temperature range -40°C / +40°C	$\tau_{Rk,ucr}$	[N/mm ²]	16,0	16,0	16,0	16,0	16,0	15,0	14,0	
Characteristic bond resistance temperature range -40°C / +55°C	$\tau_{Rk,ucr}$	[N/mm ²]	15,0	15,0	15,0	15,0	15,0	14,0	14,0	
Characteristic bond resistance temperature range -40°C / +80°C	$\tau_{Rk,ucr}$	[N/mm ²]	11,0	11,0	11,0	10,0	10,0	10,0	10,0	
Combined pull-out and concrete cone failure in non-cracked concrete C20/25 for DD										
Characteristic bond resistance temperature range -40°C / +40°C	$\tau_{Rk,ucr}$	[N/mm ²]	-	-	-	14,0	14,0	14,0	13,0	13,0
Characteristic bond resistance temperature range -40°C / +55°C	$\tau_{Rk,ucr}$	[N/mm ²]	-	-	-	13,0	13,0	13,0	12,0	12,0
Characteristic bond resistance temperature range -40°C / +80°C	$\tau_{Rk,ucr}$	[N/mm ²]	-	-	-	10,0	10,0	10,0	9,0	9,0
Reduction factor ψ_{sus}^0 for non-cracked concrete valid for all drilling method										
Sustained load factor temperature range -40°C / +40°C	ψ_{sus}^0	[-]	0,73							
Sustained load factor temperature range -40°C / +55°C	ψ_{sus}^0	[-]	0,73							
Sustained load factor temperature range -40°C / +80°C	ψ_{sus}^0	[-]	0,73							
Increasing factor for non-cracked concrete related to strength f_{ck}	ψ_c	[-]	$(f_{ck}/20)^{0,2}$							
Concrete cone failure										
Factor for non-cracked concrete	$k_{ucr,N}$	[-]	11,0							
Edge distance	$C_{cr,N}$	[mm]	1,5 h_{ef}							
Spacing	$S_{cr,N}$	[mm]	3,0 · h_{ef}							
Splitting failure										
Spacing	$S_{cr,Nsp}$	[mm]	If $h = h_{min}$							
			$S_{cr,Nsp} = 4,0 \cdot h_{ef}$							
			If $h_{min} < h < 2 h_{ef}$							
			<p style="text-align: center;">$S_{cr,Nsp} = \text{interpolate values}$</p>							
			if $h \geq 2 h_{ef}$							
$S_{cr,Nsp} = 2 h_{ef}$										
Edge distance	$C_{cr,Nsp}$	[mm]	0,5 · $S_{cr,sp}$							
Installation factor for combined pull-out, concrete cone and splitting failure										
Installation factors for category I1	γ_{inst}	[-]	1,0							
Installation factors for category I2			1,2							

BOSSONG BCR E-PLUS

Performances
 Characteristic values tension resistance load in non-cracked concrete for threaded rod under static and quasi-static loads

Annex C2
 of European
 Technical Assessment
 ETA-22/0469

Table C3: Characteristic values tension resistance load in cracked concrete for threaded rod under static and quasi-static loads for 50 and 100 years

Size	M12	M16	M20	M24	M27	M30		
Steel failure								
Characteristic resistance	$N_{Rk,s}$	[kN]	See Annex C1 – Table C1					
Partial factor	$\gamma_{Ms,N}$	[-]	See Annex C1 – Table C1					
Combined pull-out and concrete cone failure in cracked concrete C20/25 for HD – HBD and CA								
Characteristic bond resistance temperature range -40°C / +40°C	$\tau_{Rk,cr}$	[N/mm ²]	7,0	7,5	7,0	8,0	-	-
Characteristic bond resistance temperature range -40°C / +55°C	$\tau_{Rk,cr}$	[N/mm ²]	7,0	7,5	7,0	8,0	-	-
Characteristic bond resistance temperature range -40°C / +80°C	$\tau_{Rk,cr}$	[N/mm ²]	5,5	5,5	5,5	5,5	-	-
Combined pull-out and concrete cone failure in cracked concrete C20/25 for DD								
Characteristic bond resistance temperature range -40°C / +40°C	$\tau_{Rk,cr}$	[N/mm ²]	-	7,5	7,0	7,0	7,0	6,5
Characteristic bond resistance temperature range -40°C / +55°C	$\tau_{Rk,cr}$	[N/mm ²]	-	7,5	7,0	7,0	7,0	6,5
Characteristic bond resistance temperature range -40°C / +80°C	$\tau_{Rk,cr}$	[N/mm ²]	-	5,5	5,0	5,0	5,0	4,5
Reduction factor ψ_{sus}^0 for cracked concrete valid for all drilling method								
Sustained load factor temperature range -40°C / +40°C	ψ_{sus}^0	[-]	0,73					
Sustained load factor temperature range -40°C / +55°C	ψ_{sus}^0	[-]	0,73					
Sustained load factor temperature range -40°C / +80°C	ψ_{sus}^0	[-]	0,73					
Increasing factor for cracked concrete related to strength f_{ck}	ψ_c	[-]	1,00					
Concrete cone failure								
Factor for cracked concrete	$k_{cr,N}$	[-]	7,7					
Edge distance	$C_{cr,N}$	[mm]	1,5 h_{ef}					
Spacing	$S_{cr,N}$	[mm]	3,0 h_{ef}					
Splitting failure								
Spacing	$S_{cr,Nsp}$	[mm]	If $h = h_{min}$					
			$S_{cr,Nsp} = 4,0 \cdot h_{ef}$					
			If $h_{min} < h < 2 h_{ef}$					
			$S_{cr,Nsp} = \text{interpolate values}$					
if $h \geq 2 h_{ef}$								
$S_{cr,Nsp} = 2 h_{ef}$								
Edge distance	$C_{cr,Nsp}$	[mm]	0,5 · $S_{cr,sp}$					
Installation factor for combined pull-out, concrete cone and splitting failure								
Installation factors for category I1	γ_{inst}	[-]	1,0					
Installation factors for category I2			1,2					
BOSSONG BCR E-PLUS					Annex C3 of European Technical Assessment ETA-22/0469			
Performances Characteristic values tension resistance load in cracked concrete for threaded rod under static and quasi-static loads								

Table C4: Characteristic values shear resistance load – non-cracked and cracked concrete for threaded rod under static and quasi-static loads for 50 and 100 years

Size			M8	M10	M12	M16	M20	M24	M27	M30	
Steel failure without lever arm											
Characteristic resistance	$V_{Rk,s}^0$	[kN]	See Annex C1 – Table C1								
Partial factor	$\gamma_{Ms,V}$	[-]	See Annex C1 – Table C1								
Ductility factor	k_7	[-]	1,0								
Steel failure with lever arm											
Characteristic resistance	$M_{Rk,s}^0$	[kN]	See Annex C1 – Table C1								
Partial factor	$\gamma_{Ms,V}$	[-]	See Annex C1 – Table C1								
Concrete pry out failure											
Factor	k_8	[-]	2,0								
Installation factor	γ_{inst}	[-]	1,0								
Concrete edge failure											
Effective length of anchor under shear loading	l_f	[-]	$l_f = h_{ef}$ and $\leq 12 d_{nom}$						$l_f = h_{ef}$ and $\leq \max(8 d_{nom}, 300 \text{ mm})$		
Installation factor	γ_{inst}	[-]	1,0								

BOSSONG BCR E-PLUS**Performances**

Characteristic values shear resistance load in non- cracked and cracked concrete for threaded rod under static and quasi-static loads.

Annex C4
of European
Technical Assessment
ETA-22/0469

Table C5: Characteristic values tension resistance load in non-cracked concrete for rebar under static and quasi-static loads for 50 and 100 years

Size			Ø8	Ø10	Ø12	Ø14	Ø16	Ø20	Ø22	Ø25	Ø28	Ø30	Ø32	Ø40
Steel failure														
Characteristic resistance	$N_{Rk,s}$	[kN]	$A_s \times f_{uk}^{2)}$											
Cross section area	A_s	[mm ²]	50	79	113	154	201	314	380	491	616	707	804	1256
Partial factor	$\gamma_{Ms,N}^{1)}$	[-]	1,4											
Combined pull-out and concrete cone failure in non-cracked concrete C20/25 for HD – HBD and CA														
Characteristic bond resistance temperature range -40°C / +40°C	$\tau_{Rk,ucr}$	[N/mm ²]	15,0	15,0	15,0	14,0	14,0	13,0	13,0	12,0	12,0	12,0	11,0	11,0
Characteristic bond resistance temperature range -40°C / +55°C	$\tau_{Rk,ucr}$	[N/mm ²]	15,0	15,0	15,0	14,0	14,0	13,0	13,0	12,0	12,0	12,0	11,0	11,0
Characteristic bond resistance temperature range -40°C / +80°C	$\tau_{Rk,ucr}$	[N/mm ²]	10,0	10,0	10,0	10,0	10,0	9,5	9,0	9,0	9,0	9,0	7,5	7,5
Reduction factor ψ_{sus}^0 for non cracked concrete valid for all drilling method														
Sustained load factor temperature range -40°C / +40°C	ψ_{sus}^0		0,73											
Sustained load factor temperature range -40°C / +55°C	ψ_{sus}^0		0,73											
Sustained load factor temperature range -40°C / +80°C	ψ_{sus}^0		0,73											
Increasing factor for cracked concrete related to strength f_{ck}	ψ_c	[-]	$(f_{ck}/20)^{0,2}$											
Concrete cone failure														
Factor for cracked concrete	$k_{cr,N}$	[-]	11,0											
Edge distance	$C_{cr,N}$	[mm]	$1,5 h_{ef}$											
Spacing	$S_{cr,N}$	[mm]	$3,0 h_{ef}$											
Splitting failure														
Spacing	$S_{cr,Nsp}$	[mm]	If $h = h_{min}$											
			$S_{cr,Nsp} = 4,0 \cdot h_{ef}$											
			If $h_{min} < h < 2 h_{ef}$											
			<p>$S_{cr,Nsp} = \text{interpolate values}$</p>											
			if $h \geq 2 h_{ef}$											
$S_{cr,Nsp} = 2 h_{ef}$														
Edge distance	$C_{cr,Nsp}$	[mm]	$0,5 \cdot S_{cr,sp}$											
Installation factor for combined pull-out, concrete cone and splitting failure														
Installation factors for category I1	γ_{inst}	[-]	1,0											
Installation factors for category I2			1,2											

¹⁾ In the absence of other national regulation

²⁾ f_{uk} shall be taken from the specifications of reinforcing bars

BOSSONG BCR E-PLUS

Performances

Characteristic values tension resistance load in non-cracked concrete for rebar under static and quasi-static loads.

Annex C5
of European
Technical Assessment
ETA-22/0469

Table C6: Characteristic values tension resistance load in cracked concrete for rebar under static and quasi-static loads for 50 and 100 years

Size			Ø8	Ø10	Ø12	Ø14	Ø16	Ø20	Ø22	Ø25	Ø28	Ø30	Ø32	Ø40
Steel failure														
Characteristic resistance	$N_{Rk,s}$	[kN]	$A_s \times f_{tk}^{2)}$											
Cross section area	A_s	[mm ²]	50	79	113	154	201	314	380	491	616	707	804	1256
Partial factor	$\gamma_{Ms,N}^{1)}$	[-]	1,4											
Combined pull-out and concrete cone failure in cracked concrete C20/25 for HD – HBD and CA														
Characteristic bond resistance temperature range -40°C / +40°C	$\tau_{Rk,ucr}$	[N/mm ²]	8,5	8,0	8,0	8,0	8,0	7,5	7,5	7,5	7,5	7,0	7,0	6,5
Characteristic bond resistance temperature range -40°C / +55°C	$\tau_{Rk,ucr}$	[N/mm ²]	8,5	8,0	8,0	8,0	8,0	7,5	7,5	7,5	7,5	7,0	7,0	6,5
Characteristic bond resistance temperature range -40°C / +80°C	$\tau_{Rk,ucr}$	[N/mm ²]	6,0	5,5	5,5	5,5	5,5	5,0	5,5	5,0	5,0	5,0	5,0	4,5
Reduction factor ψ_{sus}^0 for cracked concrete valid for all drilling method														
Sustained load factor temperature range -40°C / +40°C	ψ_{sus}^0	[-]	0,73											
Sustained load factor temperature range -40°C / +55°C	ψ_{sus}^0	[-]	0,73											
Sustained load factor temperature range -40°C / +80°C	ψ_{sus}^0	[-]	0,73											
Increasing factor for cracked concrete related to strength f_{ck}	ψ_c	[-]	1,0											
Concrete cone failure														
Factor for non-cracked concrete	$k_{ucr,N}$	[-]	7,7											
Edge distance	$C_{cr,N}$	[mm]	1,5 h_{ef}											
Spacing	$S_{cr,N}$	[mm]	3,0 h_{ef}											
Splitting failure														
Spacing	$S_{cr,Nsp}$	[mm]	If $h = h_{min}$											
			$S_{cr,Nsp} = 4,0 \cdot h_{ef}$											
			If $h_{min} < h < 2 h_{ef}$											
			$S_{cr,Nsp} = \text{interpolate values}$											
if $h \geq 2 h_{ef}$														
$S_{cr,Nsp} = 2 h_{ef}$														
Edge distance	$C_{cr,Nsp}$	[mm]	0,5 · $S_{cr,sp}$											
Installation factor for combined pull-out, concrete cone and splitting failure														
Installation factors for category I1	γ_{inst}	[-]	1,0											
Installation factors for category I2			1,2											

¹⁾ In the absence of other national regulation

²⁾ f_{tk} shall be taken from the specifications of reinforcing bars

BOSSONG BCR E-PLUS

Performances

Characteristic values tension resistance load in cracked concrete for rebar under static and quasi-static loads.

Annex C6
of European
Technical Assessment
ETA-22/0469

Table C7: Characteristic values shear resistance load – non-cracked and cracked concrete for rebar under static and quasi-static loads for 50 and 100 years

Size			Ø8	Ø10	Ø12	Ø14	Ø16	Ø20	Ø22	Ø25	Ø28	Ø30	Ø32	Ø40		
Steel failure without lever arm																
Characteristic resistance	$V_{Rk,s}^0$	[kN]	$0,5 \times A_s \times f_{uk}^{2)}$													
Partial factor	$\gamma_{Ms,V}^{1)}$	[-]	1,5													
Cross section area	A_s	[mm ²]	50	79	113	154	201	314	380	491	616	707	804	1256		
Ductility factor	k_7	[-]	1,0													
Steel failure with lever arm																
Characteristic resistance	$M_{Rk,s}^0$	[kN]	$1,2 \times W_{el} \times f_{uk}^{2)}$													
Elastic section modulus	W_{el}	[mm ³]	50	98	170	269	402	785	1045	1534	2155	2650	3217	6283		
Partial factor	$\gamma_{Ms,V}^{1)}$	[-]	1,5													
Concrete pry out failure																
Factor	k_8	[-]	2,0													
Installation factor	γ_{inst}	[-]	1,0													
Concrete edge failure																
Effective length of anchor under shear loading	l_f	[-]	$l_f = h_{ef} \text{ and } \leq 12 d_{nom}$								$l_f = h_{ef} \text{ and } \leq \max(8 d_{nom}; 300 \text{ mm})$					
Installation factor	γ_{inst}	[-]	1,0													

BOSSONG BCR E-PLUS

Annex C7

Performances

Characteristic values shear resistance load in non-cracked and cracked concrete for rebar under static and quasi-static loads.

of European
Technical Assessment
ETA-22/0469

Table C8. Displacement under tension loads for non-cracked concrete – threaded rods under static and quasi-static loads for hammer drilling (HD), hollow drill bit (HDB) and compressed air drilling (CA)

Size			M8	M10	M12	M16	M20	M24	M27	M30
Characteristic displacement in non-cracked concrete C20/25 to C50/60 under tension loads										
Temperature range -40°C / +40°C	δ_{N0}	[mm/(N/mm ²)]	0,01	0,02	0,03	0,03	0,03	0,03	0,04	0,05
	$\delta_{N\infty}$	[mm/(N/mm ²)]	0,04	0,04	0,04	0,04	0,04	0,04	0,05	0,05
Temperature range -40°C / +55°C	δ_{N0}	[mm/(N/mm ²)]	0,01	0,02	0,03	0,03	0,03	0,03	0,04	0,05
	$\delta_{N\infty}$	[mm/(N/mm ²)]	0,05	0,05	0,05	0,05	0,05	0,05	0,05	0,05
Temperature range -40°C / +80°C	δ_{N0}	[mm/(N/mm ²)]	0,02	0,03	0,04	0,04	0,04	0,05	0,06	0,07
	$\delta_{N\infty}$	[mm/(N/mm ²)]	0,06	0,06	0,06	0,07	0,07	0,07	0,07	0,07

Table C9: Displacement under tension loads for -cracked concrete – threaded rods under static and quasi-static loads for hammer drilling (HD), hollow drill bit (HDB) and compressed air drilling (CA)

Size			M12	M16	M20	M24
Characteristic displacement in -cracked concrete C20/25 to C50/60 under tension loads						
Temperature range -40°C / +40°C	δ_{N0}	[mm/(N/mm ²)]	0,06	0,06	0,06	0,07
	$\delta_{N\infty}$	[mm/(N/mm ²)]	0,26	0,24	0,26	0,23
Temperature range -40°C / +55°C	δ_{N0}	[mm/(N/mm ²)]	0,06	0,06	0,06	0,07
	$\delta_{N\infty}$	[mm/(N/mm ²)]	0,26	0,24	0,26	0,23
Temperature range -40°C / +80°C	δ_{N0}	[mm/(N/mm ²)]	0,07	0,08	0,08	0,09
	$\delta_{N\infty}$	[mm/(N/mm ²)]	0,33	0,33	0,33	0,33

Table C10. Displacement under tension loads for non-cracked concrete – threaded rods under static and quasi-static loads for diamond drilling (DD)

Size			M16	M20	M24	M27	M30
Characteristic displacement in non-cracked concrete C20/25 to C50/60 under tension loads							
Temperature range -40°C / +40°C	δ_{N0}	[mm/(N/mm ²)]	0,02	0,03	0,03	0,03	0,04
	$\delta_{N\infty}$	[mm/(N/mm ²)]	0,05	0,05	0,05	0,05	0,05
Temperature range -40°C / +55°C	δ_{N0}	[mm/(N/mm ²)]	0,02	0,03	0,03	0,04	0,04
	$\delta_{N\infty}$	[mm/(N/mm ²)]	0,05	0,05	0,05	0,06	0,06
Temperature range -40°C / +80°C	δ_{N0}	[mm/(N/mm ²)]	0,03	0,04	0,04	0,05	0,05
	$\delta_{N\infty}$	[mm/(N/mm ²)]	0,07	0,07	0,07	0,08	0,08

Table C11. Displacement under tension loads for -cracked concrete – threaded rods under static and quasi-static loads for diamond drilling (DD)

Size			M16	M20	M24	M27	M30
Characteristic displacement in -cracked concrete C20/25 to C50/60 under tension loads							
Temperature range -40°C / +40°C	δ_{N0}	[mm/(N/mm ²)]	0,05	0,05	0,07	0,07	0,08
	$\delta_{N\infty}$	[mm/(N/mm ²)]	0,25	0,26	0,26	0,26	0,28
Temperature range -40°C / +55°C	δ_{N0}	[mm/(N/mm ²)]	0,05	0,05	0,07	0,07	0,08
	$\delta_{N\infty}$	[mm/(N/mm ²)]	0,25	0,26	0,26	0,26	0,28
Temperature range -40°C / +80°C	δ_{N0}	[mm/(N/mm ²)]	0,07	0,08	0,09	0,10	0,11
	$\delta_{N\infty}$	[mm/(N/mm ²)]	0,34	0,37	0,37	0,37	0,41

BOSSONG BCR E-PLUS

Performances
Displacement under service loads

Annex C8
of European
Technical Assessment
ETA-22/0469

Table C12: Displacement under shear loads for non-cracked and cracked concrete – threaded rods under static and quasi-static loads for all drilling method.

Size			M8	M10	M12	M16	M20	M24	M27	M30
Characteristic displacement in cracked and non-cracked concrete C20/25 to C50/60 under shear loads										
All temperature ranges	δ_{v0} factor	[mm/kN]	0,024	0,020	0,019	0,011	0,007	0,006	0,005	0,005
	$\delta_{v\infty}$ factor	[mm/kN]	0,036	0,030	0,030	0,017	0,011	0,009	0,007	0,008

Table C13: Displacement under tension loads for non-cracked concrete – rebar under static and quasi-static loads.

Size			Ø8	Ø10	Ø12	Ø14	Ø16	Ø20	Ø22	Ø25	Ø28	Ø30	Ø32	Ø40
Characteristic displacement in non-cracked concrete C20/25 to C50/60 under tension loads														
Temperature range -40°C / +40°C	δ_{N0}	[mm/(N/mm ²)]	0,02	0,02	0,03	0,03	0,03	0,04	0,04	0,05	0,06	0,06	0,07	0,07
	$\delta_{N\infty}$	[mm/(N/mm ²)]	0,05	0,05	0,05	0,05	0,05	0,05	0,05	0,06	0,06	0,06	0,06	0,06
Temperature range -40°C / +55°C	δ_{N0}	[mm/(N/mm ²)]	0,02	0,02	0,03	0,03	0,03	0,04	0,04	0,05	0,06	0,06	0,07	0,07
	$\delta_{N\infty}$	[mm/(N/mm ²)]	0,05	0,05	0,05	0,05	0,05	0,05	0,05	0,06	0,06	0,06	0,06	0,06
Temperature range -40°C / +80°C	δ_{N0}	[mm/(N/mm ²)]	0,03	0,00	0,04	0,04	0,04	0,06	0,06	0,06	0,08	0,09	0,09	0,09
	$\delta_{N\infty}$	[mm/(N/mm ²)]	0,07	0,07	0,07	0,07	0,07	0,08	0,08	0,08	0,09	0,09	0,09	0,09

Table C14: Displacement under shear loads for cracked concrete – rebar under static and quasi-static loads.

Size			Ø8	Ø10	Ø12	Ø14	Ø16	Ø20	Ø22	Ø25	Ø28	Ø30	Ø32	Ø40
Characteristic displacement in non-cracked concrete C20/25 to C50/60 under tension loads														
Temperature range -40°C / +40°C	δ_{N0}	[mm/(N/mm ²)]	0,03	0,04	0,05	0,06	0,06	0,08	0,07	0,08	0,08	0,11	0,11	0,13
	$\delta_{N\infty}$	[mm/(N/mm ²)]	0,18	0,24	0,20	0,24	0,25	0,27	0,25	0,27	0,27	0,28	0,30	0,28
Temperature range -40°C / +55°C	δ_{N0}	[mm/(N/mm ²)]	0,03	0,04	0,05	0,06	0,06	0,08	0,07	0,08	0,08	0,11	0,11	0,13
	$\delta_{N\infty}$	[mm/(N/mm ²)]	0,18	0,24	0,20	0,24	0,25	0,27	0,25	0,27	0,27	0,28	0,30	0,28
Temperature range -40°C / +80°C	δ_{N0}	[mm/(N/mm ²)]	0,04	0,06	0,07	0,08	0,08	0,11	0,10	0,11	0,12	0,15	0,15	0,18
	$\delta_{N\infty}$	[mm/(N/mm ²)]	0,25	0,34	0,28	0,33	0,35	0,38	0,35	0,38	0,38	0,39	0,42	0,39

Table C15: Displacement under shear loads for non-cracked and cracked concrete – rebar under static and quasi-static loads.

Size			Ø8	Ø10	Ø12	Ø14	Ø16	Ø20	Ø22	Ø25	Ø28	Ø30	Ø32	Ø40
Characteristic displacement in non-cracked concrete C20/25 to C50/60 under shear loads														
All temperature ranges	δ_{v0} factor	[mm/kN]	0,018	0,014	0,013	0,009	0,008	0,006	0,005	0,004	0,004	0,004	0,003	0,003
	$\delta_{v\infty}$ factor	[mm/kN]	0,027	0,022	0,019	0,014	0,012	0,009	0,008	0,006	0,006	0,005	0,005	0,005

BOSSONG BCR E-PLUS

Performances
Displacement under service loads

Annex C9
of European
Technical Assessment
ETA-22/0469

Table C16: Characteristic values tension resistance load for rebar for seismic performance category C1 for 50 and 100 years

Size			Ø10	Ø12	Ø14	Ø16	Ø20	Ø22	Ø25	Ø28	Ø30	Ø32
Steel failure												
Characteristic resistance	$N_{Rk,s}$	[kN]	$A_s \times f_{uk}^{2)}$									
Cross section area	A_s	[mm ²]	79	113	154	201	314	380	491	616	707	804
Partial factor	$\gamma_{Ms,N}^{1)}$	[-]	1,4									
Combined pull-out and concrete cone failure												
Characteristic bond resistance temperature range -40°C / +40°C	$\tau_{Rk,ucr}$	[N/mm ²]	4,0	6,0	5,7	5,7	4,6	4,6	4,6	4,6	4,6	4,6
Characteristic bond resistance temperature range -40°C / +55°C	$\tau_{Rk,ucr}$	[N/mm ²]	4,0	6,0	5,7	5,7	4,6	4,6	4,6	4,6	4,6	4,6
Characteristic bond resistance temperature range -40°C / +80°C	$\tau_{Rk,ucr}$	[N/mm ²]	2,9	4,3	4,1	4,1	3,3	3,3	3,3	3,3	3,3	3,3
Increasing factor for cracked concrete related to strength f_{ck}	Ψ_c	[-]	1,0									
Installation factor for combined pull-out, concrete cone and splitting failure												
Installation factors for category I1	γ_{inst}	[-]	1,0									
Installation factors for category I2			1,2									

¹⁾ In the absence of other national regulation

²⁾ f_{uk} shall be taken from the specifications of reinforcing bars

Table C17: Characteristic values shear resistance load for rebar for seismic performance category C1 for 50 and 100 years

Size			Ø10	Ø12	Ø14	Ø16	Ø20	Ø22	Ø25	Ø28	Ø30	Ø32
Steel failure without lever arm												
Characteristic resistance	$V_{Rk,s,eq,C1}$	[kN]	$0,64 \times V_{Rk}^0$			$0,70 \times V_{Rk}^0$			$0,62 \times V_{Rk}^0$			
Partial factor	$\gamma_{Ms,V}^{1)}$	[-]	1,5									

BOSSONG BCR E-PLUS

Performances
 Characteristic resistance under tension and shear loads for threaded rod
 for seismic action category C2

Annex C10
 of European
 Technical Assessment
 ETA-22/0469

Table C18: Characteristic values tension resistance load for threaded rod for seismic performance category C2 for 50 and 100 years

Size			M12	M16	M20	M24
Steel failure						
Characteristic resistance	$N_{Rk,s,eq,C2}$	[kN]	$1,0 \times N_{Rk,s}$			
Partial factor	$\gamma_{Ms,N}$	[-]	See Annex C1 – Table C1			
Combined pull-out and concrete cone failure						
Characteristic bond resistance temperature range -40°C / +40°C	$\tau_{Rk,C2}$	[N/mm ²]	5,4	5,3	5,5	5,4
Characteristic bond resistance temperature range -40°C / +55°C	$\tau_{Rk,C2}$	[N/mm ²]	5,4	5,2	5,5	5,4
Characteristic bond resistance temperature range -40°C / +80°C	$\tau_{Rk,C2}$	[N/mm ²]	3,9	3,8	3,9	3,9
Increasing factor related to concrete strength f_{ck}	ψ_c	[-]	1,0			
Installation factors for category I1	γ_{inst}	[-]	1,0			
Installation factors for category I2			1,2			

Table C19: Characteristic values shear resistance load for threaded rod for seismic performance category C2 for 50 and 100 years

Size			M12	M16	M20	M24
Steel failure						
Characteristic resistance	$V_{Rk,s,eq,C2}$	[kN]	$0,54 \times V_{Rk,s}^0$	$0,55 \times V_{Rk,s}^0$	$0,68 \times V_{Rk,s}^0$	$0,59 \times V_{Rk,s}^0$
Partial factor ¹⁾	$\gamma_{Ms,V}$	[-]	See Annex C1 – Table C1			

Table C20: Reduction factor for annular gap.

Reduction factor for annular gap						
Without annular gap filling	α_{gap}	[-]	0,5			
With annular gap filling	α_{gap}	[-]	1,0			

Table C21: Displacements for tensile and shear load for seismic performance category C2 - threaded rod.

Size			M12	M16	M20	M24
Displacements for tensile and shear load for seismic performance category C2						
Displacement in tensile at damage limitation states	$\delta_{N,eq,seis} (DLS)$	[mm]	0,22	0,27	0,92	0,54
Displacement in tensile at ultimate limit state	$\delta_{N,eq,seis} (ULS)$	[mm]	0,28	0,66	1,70	0,93
Displacement in shear at damage limitation states	$\delta_{V,eq,seis} (DLS)$	[mm]	1,64	0,81	2,39	2,21
Displacement in shear at ultimate limit state	$\delta_{V,eq,seis} (ULS)$	[mm]	3,96	4,29	7,29	7,42

BOSSONG BCR E-PLUS

Performances
 Characteristic resistance under tension and shear loads for threaded rod
 for seismic action category C2

Annex C11
 of European
 Technical Assessment
 ETA-22/0469